



The 3-Kilo Millennium Coffee Roaster

Hand Built Quality



- | | | |
|--------------------------|--------------------|----------------------------------|
| <input type="checkbox"/> | 3kiloMill Gas | 120V/ 20amps |
| <input type="checkbox"/> | 3kiloMill Gas | Single Phase / 208-240V/ 10amps |
| <input type="checkbox"/> | 3kiloMill Electric | Single Phase / 208-240V / 50amps |

NEW FOR 2025! 4 motors Stainless cooler liner, 4" magnehelic gauges for air flow and gas pressure, digital environmental air temp gauge, improved air dampener control, Bean light, Easy service, Improved quiet gear drives and mounts. Drum Speed Drive is included. Fidget for data logging!

NEW Microcontroller based touchscreen profiler model with real-time graphing and an easy to use interface!

FRAME

- Heavy-duty stainless steel drum, cooler screen, and cooler liner
- Double insulated housings. Full Chaff Collector
- Easy to service roaster fan / includes chaff cyclone
- Removable cooler for easy cleaning
- Industrial gear drives for smooth operation of drum and cooler stirrer, with no bulky belts or noisy dangerous chains.
- Equipped with heavy duty direct drive steel-cooling fan.
- Heavy-duty motors with UL 508-A approved industrial control system and motors, adjustable overloads and contactors.
- Adjustable legs for ease of movement
- Magnetic in cooler discharge

OPERATION

- 24 volt operator controls for safe operation. UL 508Ac listed
- Even and accurate heat controls;
- Cast iron rectangular burners or industrial electric elements with full chaff collector. Fan suction gauge included
- Standard lighted push button on-off switches, motor starters and overloads with fault protection.
- Two gas gauges provided for incoming gas pressure and four inch outgoing gauge at gate valve to adjust burner output.
- Profiler model has programmable and digital control
- All models include digital bean probe and air temperature with controller and alarm and environment temp gauge
- Free Training in OKC, Live Tech Support!
- We offer several different upgrades for amassing automation
- ULc -508a industrial listing, Safety Cooler Slip Clutch.

SPECIFICATIONS

3 Kilo Model (7.5lb) Coffee Roaster. 4-5 roasts per hour. Designed for easy operation, low maintenance, and a long lifetime. Your choice of several standard colors, trim types and finishes.

- Weight: 450 lbs.
- Total Dimensions¹: 24"x43"x53" (LxWxH) add 14" in length if you use the external cyclone.
- Shipping: 600 lbs. 42"x52"x55" (LxWxH)
- Piping²: 4-6" Stainless or Class A
- Gas model averages about 15,000 BTUs with a
- Gas Supply: Nat'l Gas minimum 7" w.c. Propane or Propane Butane mix 14" w.c.
- USRC designed with highest quality parts and best metals, supported by the people that designed it for roasting award winning coffee.

Full Chaff collector supplied or integrated on request

[1] Allow 18" clearance minimum for service

[2] Vent Class A 4" pipe can also be used with 6" please order the roaster for the vent size needed.

[3] **Special note for Propane or bottled gas**, it is highly recommended for your safety that you purchase a quality propane regulator from a Professional source. You must have the correct regulator for the type of supply that you are connecting the roaster to. Changing supply type can or not having the regulator set to the pressure needs of the roaster or the source can be safety hazard and also damage the roaster. If you have needs for regulator please contact one of our Engineering staff for the correct one.



The 3-Kilo Millennium Coffee Roaster

Patent Pending

Hand Built Quality

Models

- 3-Kilo Stock Model, Best for tight locations \$17,998
- 3 kilo stock with twin fans and chaff collector \$18,960
- 3-K stock with micro Profiler and bean lite \$20,950
- 3-Kilo Standard Model (includes Stainless or copper drum and cooler wrap and bean light Dual Fans \$19,875
- 3-Kilo Deluxe includes standard model features and 10" color touch screen with automation and profiling includes all the features of the Standard \$21,995

Add-ons

- Microcontroller Based Touchscreen Profiler \$1500
- Semi-Automatic
- Fingertip control for fan and drum speed
- Roast Helper Option

Touchscreen Profiler Options

- 10" color touch screen with extended profiles included**
- Wireless touchscreen to connect to iPhone/iPad

Aesthetic Options

- Stainless polished cooler included
- Hammered copper cooler outer skin
- Stainless or hammered copper drum wrap

Aesthetic Options (continued)

- Pin striping
- Two tone paint included
- Clear coat over paint with metal flake
- Custom paint color
- Chrome bean chute

Operational Options

- Electric roaster door with override and auto discharge (non PLC)
- Automatic quenching for drum or cyclone
- Maintenance hour meter
- Roast timer
- Bean light included on all models
- Roaster drum speed control included on all models
- Cleaning kit
- Roaster controls on control head
- Fan speed controller
- Magnets in cooler discharge included on all models.
- Micro controller
- Quench in cyclone and drum.

About Us. The U.S. Roaster Corp. is famous for producing the world's finest roasters that create the best roasted coffee. Partnering with specialty coffee roast masters world-wide we have developed a roaster of superior design, unmatched quality, great reliability, and ease of use. Our Millennium line of roasters provide the roast master with unlimited profile capabilities and unparalleled roast quality. By the second crack you will know why the "Quality of the Roast" comes first at U.S. Roaster Corp.

Free One-on-one training session is provided in Oklahoma City!

Contact us for information

1530 West Main St.
 Oklahoma City, OK. 73106
 405.232.1223.
dan@roastersexchange.com
www.usroastercorp.com

All local codes to be followed on install.

We reserve the right to make changes due to ongoing improvements.

US Roaster Corp

1530 West Main Street ■ Oklahoma City, OK 73106 ■ Phone: 405.232.1223
 Fax: 405.232.1255 ■ Email: dan@roastersexchange.com

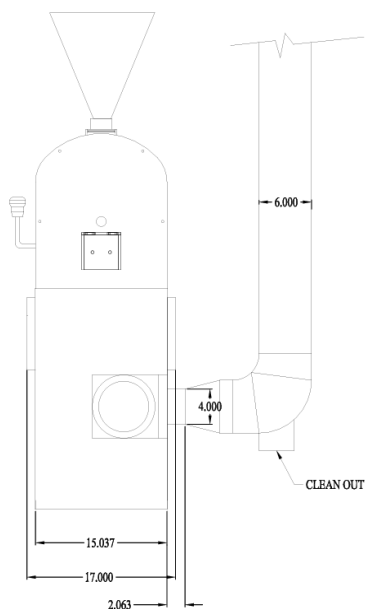
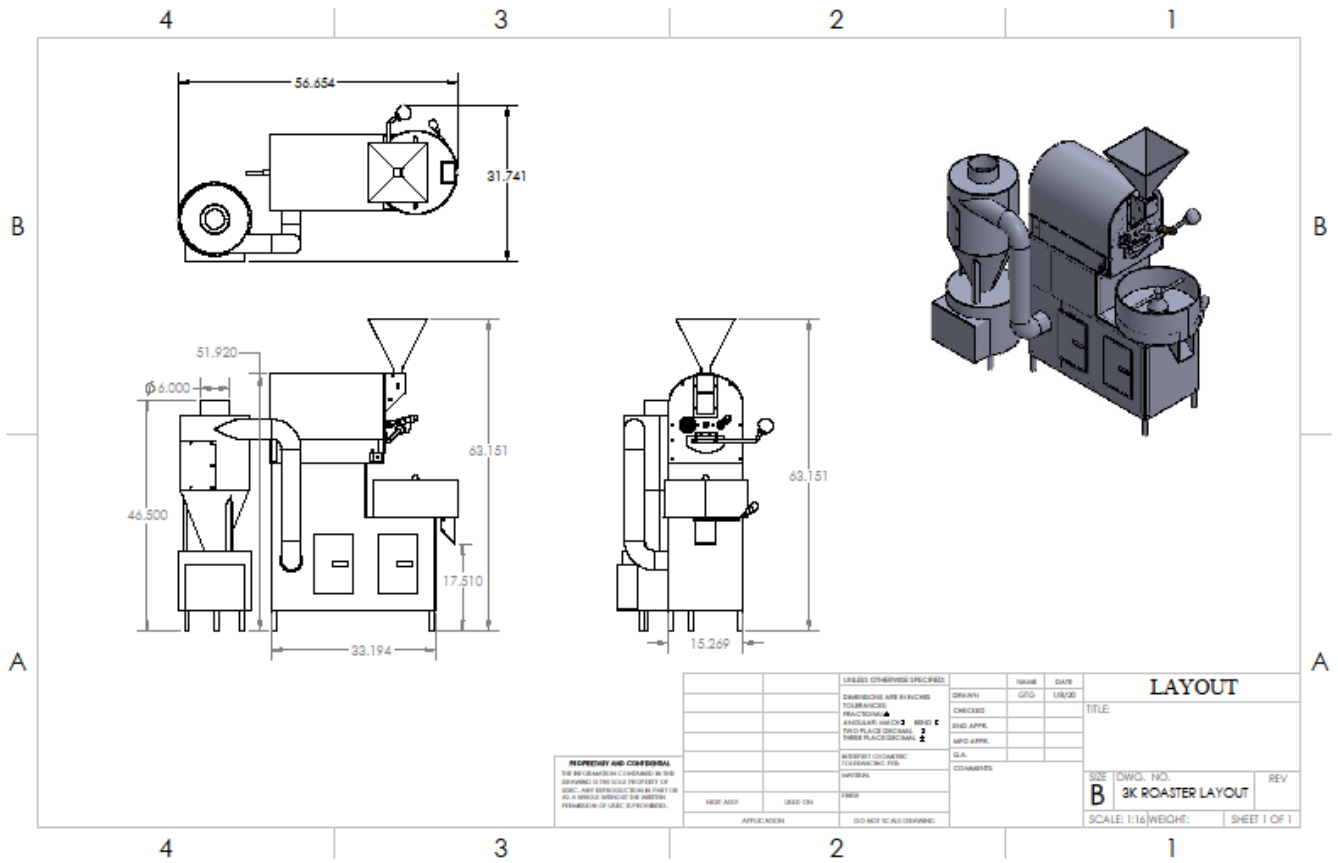

REAR SIDE

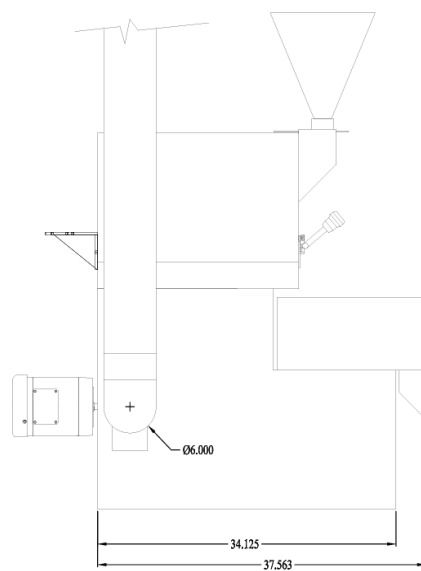

EXHAUST SIDE