



The 12-Kilo Millennium Coffee Roaster

Patent Pending

American Made, Hand Built Quality



SPECIFICATIONS

12 Kilo Model (30lb) Coffee Roaster. Four Med roasts per hour. Designed for easy operation, low maintenance, and a long lifetime. Your choice of several standard colors, trim types and finishes.

- Weight: 1350 lbs with professional Cyclone.
- Total Dimensions¹: 71"x31"x71"(LxWxH)
- Cyclone Exhaust: 6" Cooler Exhaust: 5"²
- 10,000—90,000 BTUs adjustable
- Gas Supply: 3/4" Pipe with Natural at 9" w.g. or Propane at 13" w.g.
- Quenching requires a 3/8th inch filtered water line (for applicable models)
- Open Frame shown above High performance!

[1] Allow 18" clearance minimum for service. Dimensions do not include chaff collector

[2] Use Class A type positive pressure piping

[3] **Special note for Propane or bottled gas.** it is highly recommended for your safety that you purchase a quality propane regulator from a Professional source. You must have the correct regulator for the type of supply that you are connecting the roaster to. Changing supply type can or not having the regulator set to the pressure needs of the roaster or the source can be safety hazard and also damage the roaster. If you have needs for regulator please contact one of our Engineering staff for the correct one.

- | | | |
|--------------------------|---------------------|---|
| <input type="checkbox"/> | 12kiloMill Gas | 3-Phase / 208-240 V / 15amps |
| <input type="checkbox"/> | 12kiloMill Gas | Single Phase / 208-240 V / 20amps |
| <input type="checkbox"/> | 12kiloMill Electric | Single Phase / 208-240 V / 120 amps |
| <input type="checkbox"/> | 12kiloMill Electric | 3-Phase / 208-240V / 75amps / 380V / 50 amps / 480V / 40 amps |

NEW FOR 2024! Stainless cooler, can be painted 4" magnehelic gauges, fidget installed for data logging, digital environmental air temp gauge, and Magnetics in Cooler discharge, Bean light with ~~Drum Speed Drive. Stainless Cooler~~
FRAME

- Heavy-duty double wrapped and ground stainless steel drum,
- Double insulated housings. Adjustable housing for drum bearing
- Easy to service roaster fan and fast Cooling with dedicated fan.
- Removable cooler for easy cleaning with adjustable slip clutch
- Industrial gear drives for smooth operation of drum and cooler stirrer, no bulky belts or noisy chains. Super Quiet Operation
- Equipped with heavy duty direct drive steel-cooling fan.
- Heavy-duty motors with UL 508-A approved industrial control system and motors, adjustable overloads and contactors.
- Adjustable legs for ease of movement and cleaning
- Easy to adjust housing for the main drum bearing in designed to keep the bearing cooler and lubricated
- Grooved faceplate to seal drum for less product loss
- Water jet and precision milled steel parts made in-house

OPERATION

- 24 volt operator controls for safe operation.
- Even and accurate heat controls;
- Heavy duty burners with a large venture mixer or industrial electric elements, Safety Slip Clutch on cooler no need for cover
- Free Standing cyclonic chaff collector.
- Standard lighted push button on-off switches, motor starters and overloads with fault protection.
- Two gas gauges provided for incoming gas pressure and outgoing gauge at gate valve to adjust burner output.
- Profiler model has programmable and digital control 8" color.
- All models include digital bean probe with controller and alarm and environment temp gauge, Fan suction manometer

US Roaster Corp

1530 West Main Street ■ Oklahoma City, OK 73106 ■ Phone: 405.232.1223
Fax: 405.232.1255 ■ Email: dan@roastersexchange.com



The 12-Kilo, 30 pound Millennium Coffee Roaster

Patent Pending

American Made, Hand Built Quality**Models**

- 12-Kilo Stock Model fully equipped ready to roast \$39,995
- 12 kilo Stock with Micro automation/profiling \$41,950
- 12-Kilo Standard Model includes polished Stainless Drum and Cooler or in patterned Copper and bean light \$40,957
- 12-Kilo Open Frame Model includes fan speed \$40,950
- 12-Kilo Deluxe Model includes automation and 8" touch screen profiling and Standard model options \$47,550

Add-ons

- Touchscreen Profiler
- Semi-Automatic
- Fingertip control add \$900
- Roast Helper Option

Touchscreen Profiler Options

- Large PLC memory for 999 profiles
- Wireless touchscreen to connect to iPhone/iPad
- 10 in color display standard
- Operation of Afterburners, destoners and other equipment
- Air gates on cooler discharge or green bean hopper

Additional Options

- Electric roaster door with override and auto discharge (non PLC)
- Stainless polished cooler included

Additional Options (continued)

- Smooth or dimensional stainless or hammered copper drum wrap
- Dimensional patterned stainless drum wrap
- Hammered copper cooler wrap
- Pin striping
- Two tone paint no charge
- Clear coat over paint with metal flake
- Maintenance hour meter
- Digital roast timer
- Environmental air temperature with digital read-out
- Automatic quenching for drum or cyclone
- Chrome bean chute
- Chrome face plate
- Bean light (110 V only)
- Drum speed control included
- Custom paint color
- Cleaning kit
- Roaster controls on control head
- Magnet in cooler discharge
- Destoner
- Afterburner integrated with smart fuel saving control / Several types including Catalytic.
- Left hand or right hand control your choice.

About Us. The U.S. Roaster Corp. is famous for producing the world's finest roasters that create the best roasted coffee. Partnering with specialty coffee roast masters world-wide we have developed a roaster of superior design, unmatched quality, great reliability, and ease of use. Our Millennium line of roasters provide the roast master with unlimited profile capabilities and unparalleled roast quality. By the second crack you will know why the "Quality of the Roast" comes first at U.S. Roaster Corp.

Free One-on-one training session is provided in Oklahoma City!

Contact us for information

1530 West Main St.
Oklahoma City, OK. 73106
405.232.1223.
dan@roastersexchange.com
www.usroastercorp.com

All local codes to be followed on install.

We reserve the right to make changes due to ongoing improvements.
Please ask us for disconnect and fuse sizing

US Roaster Corp

1530 West Main Street ■ Oklahoma City, OK 73106 ■ Phone: 405.232.1223
Fax: 405.232.1255 ■ Email: dan@roastersexchange.com

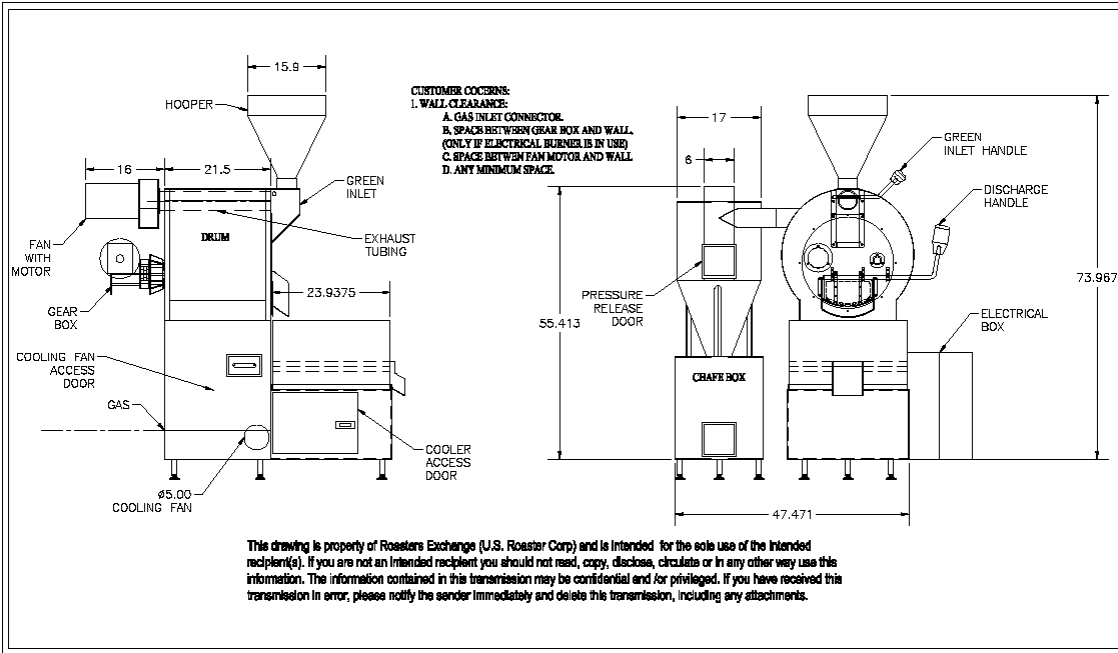

This drawing is property of Roasters Exchange (U.S. Roaster Corp) and is intended for the sole use of the intended recipient(s). If you are not an intended recipient you should not read, copy, disclose, circulate or in any other way use this information. The information contained in this transmission may be confidential and/or privileged. If you have received this transmission in error, please notify the sender immediately and delete this transmission, including any attachments.

REV	REVISION	DATE	TITLE: WELD ON HINGE	US ROASTER CORP. <small>1801 1/2 W. 15th St. Oklahoma City, OK 73104</small> <small>www.usroaster.com</small>	FABRICATION NUM. NO.
LET			MATERIAL: MILD STEEL		PRESENTATIONAL
TOLERANCES UNLESS OTHERWISE NOTED			DRN. BY: RBG	DATE: 6/12/12	FABRICATION REF. NAME
DECIMAL	FRACTIONAL	ANGULAR	CHK. BY	DATE	
± .00125	± 1/32	± .005°	APPD. BY	DATE	SCALE: 1:1

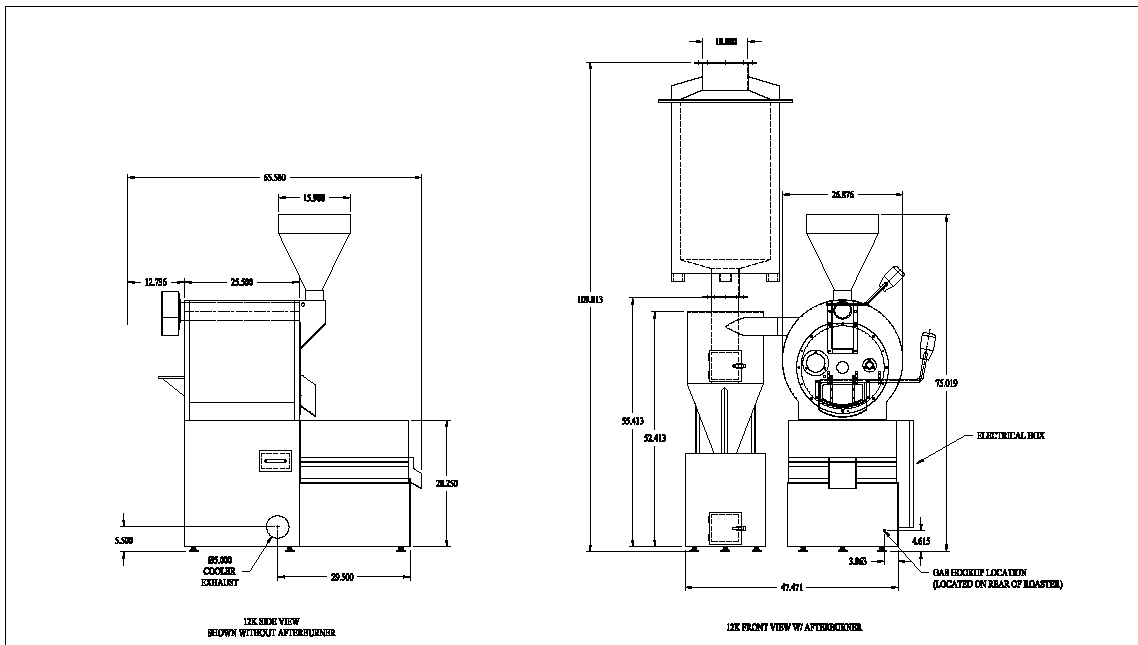

TOLERANCES UNLESS OTHERWISE NOTED			DRN. BY: RBG	DATE: 06/12/12	TITLE
DECIMAL	FRACTIONAL	ANGULAR	CHK. BY	DATE	12 KILO ROASTER
± .00125	± 1/32	± .005°	APPD. BY	DATE	ASSEMBLY VIEWS
Roasters Exchange			SCALE: NONE		DRAWING NO.
1530 West 14th Oklahoma City, Ok 73108					RE120417-001A
LET	REV	DATE			

Afterburner's and set are often custom designed for Customer needs please double check prints and get an "as built" Drawing for your planning